

# KUSTOM®

## OWNERS MANUAL MODEL HV™ 65



**Congratulations** on the purchase of your new Kustom® High Voltage HV™ Series guitar amplifier. This model utilizes an exclusive preamp design that combines a 12AX7 tube, known for its robust tonal qualities, with solid-state circuitry that provides consistency of performance and reliability. The result is rich, dynamic tone that is perfect for a wide variety of playing styles and environments. Inside this manual you'll find details about your HV Series model. Everyone at Kustom wishes you many years of enjoyment with your new amplifier!



# ENGLISH

## Danger

Exposure to extremely high noise levels may cause a permanent hearing loss. Individuals vary considerably to noise induced hearing loss but nearly everyone will lose some hearing if exposed to sufficiently intense noise for a sufficient time.

The U.S. Government's Occupational Safety and Health Administration (OSHA) has specified the following permissible noise level exposures:

|                          |    |    |    |    |     |     |
|--------------------------|----|----|----|----|-----|-----|
| DURATION PER DAY (HOURS) | 8  | 6  | 4  | 3  | 2   | 1   |
| SOUND LEVEL (dB)         | 90 | 93 | 95 | 97 | 100 | 103 |

According to OSHA, any exposure in the above permissible limits could result in some hearing loss. Ear plugs or protectors in the ear canal or over the ears must be worn when operating this amplification system in order to prevent a permanent hearing loss. If exposure in excess of the limits as put forth above, to insure against potentially harmful exposure to high sound pressure levels, it is recommended that all persons exposed to equipment capable of inducing high sound pressure levels, such as this amplification system, be protected by hearing protectors while this unit is in operation.

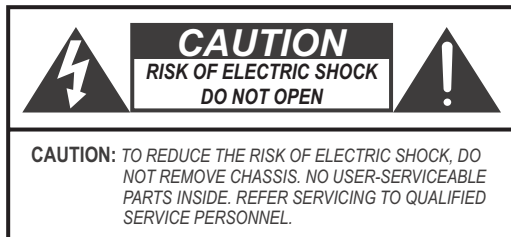

### AVIS: RISQUE DE CHOC ELECTRIQUE-NE PAS OUVRIR.



THIS SYMBOL IS INTENDED TO ALERT THE USER TO THE PRESENCE OF NON-INSULATED "DANGEROUS VOLTAGE" WITHIN THE PRODUCT'S ENCLOSURE THAT MAY BE OF SUFFICIENT MAGNITUDE TO CONSTITUTE A RISK OF ELECTRIC SHOCK TO PERSONS.



THIS SYMBOL IS INTENDED TO ALERT THE USER TO THE PRESENCE OF IMPORTANT OPERATING AND MAINTENANCE (SERVICING) INSTRUCTIONS IN THE LITERATURE ACCOMPANYING THE UNIT.



APPARATUS SHALL NOT BE EXPOSED TO DRIPPING OR SPLASHING AND THAT NO OBJECTS FILLED WITH LIQUIDS, SUCH AS VASES, SHALL BE PLACED ON THE APPARATUS.

## IMPORTANT SAFETY INSTRUCTIONS

1. Read all safety and operating instructions before using this product.
2. All safety and operating instructions should be kept for future reference.
3. Read and understand all warnings listed on the operating instructions.
4. Follow all operating instructions to operate this product.
5. This product should not be used near water, i.e. Bathtub, sink, swimming pool, wet basement, etc.
6. Only use dry cloth to clean this product.
7. Do not block any ventilation openings, It should not be placed flat against a wall or placed in a built-in enclosure that will impede the flow of cooling air.
8. Do not install this product near any heat sources ;such as, radiators, heat registers, stove or other apparatus (including heat producing amplifiers) that produce heat.
9. Do not defeat the safety purpose of the polarized or grounding-type plug. A polarized plug has two blades with one wider than the other. A grounding-type plug has two blades and a third grounding prong. The wide blade or the third prong are provided for your safety. If the provided plug does not fit into your outlet, consult an electrician for replacement of the obsolete outlet.
10. Protect the power cord being walked on or pinched, particularly at Plugs, convenience receptacles and the point where they exit from the apparatus. Do not break the ground pin of the power supply cord.
11. Only use attachments specified by the manufacturer.
12. Use only with the cart, stand, tripod, bracket, or table specified by the manufacturer or sold with the apparatus. When a cart is used, use caution when moving cart/ apparatus combination to avoid injury from tip-over. 
13. Unplug this apparatus during lightning storms or when unused for long periods of time.
14. Care should be taken so that objects do not fall and liquids are not spilled into the unit through the ventilation ports or any other openings.
15. Refer all servicing to qualified service personnel. Servicing is required when the apparatus has been damaged in any way; such as, power-supply cord or plug is damaged, liquid has been spilled or objects have fallen into the apparatus, the apparatus has been exposed to rain or moisture, does not operate normally or has been dropped.
16. WARNING: To reduce the risk of fire or electric shock, do not expose this apparatus to rain or moisture.
17. The MAINS plug or an appliance coupler is used as the disconnect device, the disconnect device shall remain readily operable.

# FRENCH

## Danger

L'exposition a des niveaux eleves de bruit peut provoquer une perte permanente de l'audition, Chaque organisme humain reagit differemment quant a la perte de l'audition, mais quasiment tout le monde subit une diminution de l'acuite auditive lors d'une exposition suffisamment longue au bruit intense. Les autorites competentes en reglementation de bruit ont defini les expositions tolerees aux niveaux de bruits:

|                              |    |    |    |    |     |     |
|------------------------------|----|----|----|----|-----|-----|
| DURE EN HEURES PAR JOUR      | 8  | 6  | 4  | 3  | 2   | 1   |
| INIVEAU SONORE CONTINU EN dB | 90 | 93 | 95 | 97 | 100 | 103 |

Selon les autorites, toute exposition dans les limites citees ci-dessus, peuvent provoquer certaines pertes d'audition. Des bouchons ou protections dans l'appareil auditif ou sur l'oreille doivent etre portes lors de l'utilisation de ce systeme d'amplification afin de prevenir le risque de perte permanente de l'audition, Dans le cas d'expositions superieures aux limites precitees il est recommande, afin de se premunir contre les expositions aux pressions acoustiques elevees potentiellement dangeereuses, aux personnes exposees aux equipements capables de delivrer de telles puissances, tels ce systeme d'amplification en fonctionnement, de proteger l'appareil auditif.



CE SYMBOLE A POUR BUT D'AVERTIR L'UTILISATEUR DE LA PRESENCE DE VOLTAGE DANGEREUX NON-ISOLE A L'INTERIEUR DE CE PRODUIT QUI PEUT ETRE DE PUISSANCE SUFFISAMMENT IMPORTANTE POUR PROVOQUER UN CHOC ELECTRIQUE AUX PERSONNES.



CE SYMBOLE A POUR BUT D'AVERTIR L'UTILISATEUR DE LA PRESENCE D'INSTRUCTIONS D'UTILISATION ET DE MAINTENANCE DANS LES DOCUMENTS FOURNIS AVEC CE PRODUIT.



AFIN DE REDUIRE LES RISQUE D'INCENDIE ET DE DECHARGE ELECTRIQUE, NE PAS EXPOSER CET APPAREIL A LA PLUIE OU A L'HUMIDITE.

## IMPORTANTES INSTRUCTIONS DE SECURITE

1. Lire avec attention toutes les recommandations et precautions d'emploi avant d'utiliser ce produit.
2. Toutes les recommandations et precautions d'emploi doivent etre conservees afin de pouvoir s'y reporter si necessaire.
3. Lire et comprendre tous les avertissements enumerés dans les precautions d'emploi.
4. Suivre toutes les precautions d'emploi pour utiliser ce produit.
5. Ce produit ne doit pas etre utilise pres d'eau, comme par exemple baignoires, eviers, piscine, sous-sol humides ... Etc.
6. Utiliser exclusivement un chiffon sec pour nettoyer ce produit.
7. Ne bloquer aucune ouverture de ventilation. Ne pas placer le produit tout contre un mur ou dans une enceinte ferree, cela generait le flux d'air necessaire au refroidissement.
8. Ne pas placer le produit pres de toute source de chaleur telle que radiateurs, arrivees d'air chaud, fourneaux ou autres appareils generant de la chaleur (incluant les amplificateurs producteurs de chaleur) .
9. Ne pas negliger la securite que procure un branchement polarise ou avec raccordement a la terre, Un branchement polarise comprend deux fiches dont l'une est plus large que l'autre. Un branchement a la terre comprend deux fiches plus une troisieme reliee a la terre. Si la fiche secteur fournie ne s'insert pas dans votre prise de courant. consulter un 'electricien afin de remplacer votre prise obsolete.
10. Protéger le cordon d'alimentation de tout ecrasement ou pincement, particulierement au niveau des fiches, des receptacles utilises et a l'endroit de sortie de l'appareil. Ne pas casser la fiche de terre du cordon d'alimentation.
11. Utiliser uniquement les accessoires specifies par le constructeur.
12. Utiliser uniquement avec le chariot de transport, le support, le trepied, la console ou la table specifies par le constructeur ou vendus avec l'appareil. Lors de l'utilisation d'un chariot, bouger avec precaution l'ensemble chariotlappareil afin d'éviter les dommages d'un renversement.
13. Débrancher cet appareil lors d'orages ou s'il n'est pas utilise pendant une longue periode.
14. Des precautions doivent etre prises afin qu'aucun objet ne tombe et qu'aucun liquide ne se repande a l'interieur de l'appareil par les orifics de ventilation ou n'importe quelle autre ouverture.
15. Pour toutes interventions techniques s'adresser a un technicien qualifie. L'intervention technique est necessaire lorsque l'appareil a ete endommage de n'importe quelle facon, comme par exemple si le cordon secteur ou sa fiche sont deteries, si du liquide a coule ou si des objets sont tombes a l'interieur de l'appareil, si l'appareil a ete expose a la pluie ou a l'humidite, s'il ne fonctionne pas normalement ou s'il est tombe.
16. ATTENTION: Pour reduire le risque d'incendie ou de choc electrique ne pas exposer l'appareil a la pluie ou a l'humidite.
17. La prise Mains, au coupler, est utilise pour la source d'alimentation electrique. Il est conseille de garder cette prise facilement accessible.



# HV™ 65 CONTROL PANEL FUNCTIONS

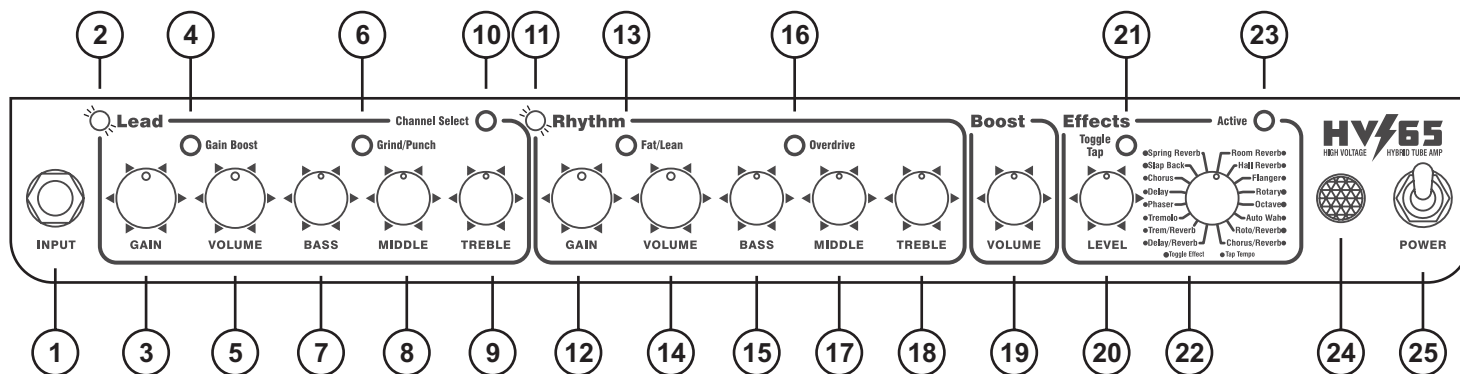

- 1.) **Guitar Input Jack** - this is a 1/4" 2-conductor input jack for plugging in your instrument. It is intended for guitars but will accept other instruments as well.
- 2.) **Lead Channel On LED** - when this LED light is on, it indicates that the Lead Channel is active.
- 3.) **Gain** - adjust this clockwise to increase the amount of distortion. Lower ranges of the control, you get a less distorted sound. As you increase the gain, you add tremendous amounts of distortion to the signal for a harder edged "crunch" tone.
- 4.) **Gain Boost Switch** - this switch will add more gain to the Lead Channel.
- 5.) **Volume** - this is a volume control for the Lead Channel ONLY.
- 6.) **Grind/Punch Switch** - this switch selects either the PUNCH or GRIND preamps. Each preamp offers a different tonal variation.
- 7.) **Bass** - this control is the bass control for the Lead Channel. It is passive and set to shelve frequencies at 100Hz. Turning it fully clockwise, the signal is unaltered. Turning it counterclockwise, the low will be rolled off -12db.
- 8.) **Middle** - this control is the midrange control for the for the Lead Channel, and is passive and set to shelve frequencies at 1KHz. Turning it fully clockwise, the signal is unaltered. Turning it counterclockwise, the low will be rolled off - 12db.
- 9.) **Treble** - this is the high frequency tone control for the Lead Channel. It is passive and set to shelve frequencies at 3KHz on the instrument channel. Turning it fully clockwise, the signal is unaltered. Turning it counterclockwise, the highs will be rolled off - 12db.
- 10.) **Channel Select Switch** - this switch selects between the Lead or Rhythm Channel.
- 11.) **Rhythm Channel On LED** - when this LED light is on, it indicates that the Rhythm Channel is active.
- 12.) **Gain** - adjust this clockwise to increase the amount of gain of the Rhythm Channel. The gain is applied before the tone controls.
- 13.) **Fat/Lean** - Selecting Fat allows the 12AX7 tube input stage to be over-driven, giving a fatter sound.
- 14.) **Volume** - this is a volume control for the Rhythm Channel only.
- 15.) **Bass** - this control is the bass control for the Rhythm Channel. It is passive and set to shelve frequencies at 100Hz. Turning it fully clockwise, the signal is unaltered. Turning it counterclockwise, the low will be rolled off -12db.
- 16.) **Overdrive** - this increases the gain of the second stage of the 12AX7 preamp tube on the Rhythm Channel.
- 17.) **Middle** - this control is the midrange control for the Rhythm Channel, and is passive and set to shelve frequencies at 1KHz. Turning it fully clockwise, the signal is unaltered. Turning it counterclockwise, the low will be rolled off - 12db.
- 18.) **Treble** - this is the high frequency tone control for the Rhythm Channel. It is passive and set to shelve frequencies at 3KHz on the instrument channel. Turning it fully clockwise, the signal is unaltered. Turning it counterclockwise, the highs will be rolled off - 12db.
- 19.) **Boost** - this is a master volume for both the Lead and Rhythm Channels. It's an overall volume control for the amplifier.
- 20.) **Effects Level** - this control adds the digital effects section and mixes it into the main signal. Sixteen different effects are available.
- 21.) **Toggle Tap** - This momentary switch performs different functions, depending on which effect is selected. Page 6 describes each effect in detail and how to enhance its usefulness with this switch.
- 22.) **Program Select** - this switch will select any of sixteen different effects. Page 6 describes each effect in detail.
- 23.) **Effects Active** - this switch engages the digital effects section. The footswitch over-rides this switch when it's plugged into the amp.
- 24.) **Jewel Light** - this jewel light lets you know that the amplifier is on.
- 25.) **Power Switch** - this switch turns on and off the AC power to the amp.

# HV™ 65 Effects

**Effects Level** this control adds the digital effects section and mixes it into the main signal. Sixteen different effects are available.

**Program Select** this switch will select any of the sixteen different effects.

**Effects Active** this switch engages the digital effects section. The footswitch over-rides this switch when it's plugged into the amp.

**Toggle Tap** this switch is a dual function depending on which effects program is selected. On “toggle” effects, this button pages through alternate variations of the effect. For example, for the Spring Reverb, it pages through 3 different degrees of brightness. On “tap” effects, this button selects the rate time at which the effect cycles, by tapping the switch twice. For example, for the Delay setting, it selects the amount of time between delay repeats (If the 2<sup>nd</sup> tap is beyond the maximum setting, the time will default to the longest available choice).

| Effect Program | Description   | Toggle | Tap | Toggle Tap Function                                    |
|----------------|---|--------|-----|--|
| Spring Reverb  | simulates the spring reverb pan found in vintage tube amps      | X      |     | pages through 3 different degrees of reverb brightness |
| Slap Back      | a fast 80ms delay for getting those Rockabilly tones            | X      |     | toggles between Slapback and Slapback/Reverb           |
| Chorus         | a beautiful thick chorus that can swish with the best of them   |        | X   | adjusts chorus rate time                               |
| Delay          | an organic sounding delay that has that analog warmth           |        | X   | adjusts delay time....maximum delay = 680 mS           |
| Phaser         | a sweet and swooshy '70s sounding phaser                        |        | X   | adjusts phaser rate time                               |
| Tremolo        | a classic sounding tremolo with a hint of vibrato               |        | X   | adjusts tremolo rate time                              |
| Trem/Reverb    | a combination effect of tremolo and room reverb                 |        | X   | adjusts tremolo rate time                              |
| Delay/Reverb   | a combination effect of the delay and room reverb               |        | X   | adjusts delay time....maximum delay = 350 mS           |
| Room Reverb    | the reverb sound of your amp being played in a room             |        | X   | adjusts reverb decay time                              |
| Hall Reverb    | the reverb sound of your amp being played in a large hall       |        | X   | adjusts reverb decay time                              |
| Flanger        | a deep flanger for getting those spacey sweeping tones          |        | X   | adjusts flanger rate time                              |
| Rotary         | gives you that twirling sound of those fancy old organ cabinets | X      |     | ramps between fast and slow rotary speeds              |
| Octave         | shifts the pitch up or down one octave from the original signal | X      |     | toggles between octave up and octave down              |
| Auto Wah       | a wah wah that automatically sweeps at your chosen speed        |        | X   | adjusts auto wah rate time                             |
| Roto/Reverb    | a combination effect of Rotary with room reverb                 | X      |     | ramps between fast and slow rotary speeds              |
| Chorus/Reverb  | a combination effect of chorus and room reverb                  |        | X   | adjusts chorus rate time                               |

**Effects Module Memory** Aside from all the versatility of the built-in effects, the effects module in your Kustom amplifier has the ability to store your favorite sounds. All the most recent changes to the Toggle Tap button are saved in each of the 16 effect locations. For example, If you tap in your favorite delay time, then go to chorus, and then go back to delay, your own tapped delay time will still be saved. These setting changes are also retained when powering down the amplifier.

**To Restore Factory Settings** If you ever want to restore the effects to the factory default settings, you can do this by selecting Program 1 (Delay/Reverb), then holding the tap switch down and simultaneously selecting Program 2 (Trem/Reverb).

# HV™ 65 Back Panel

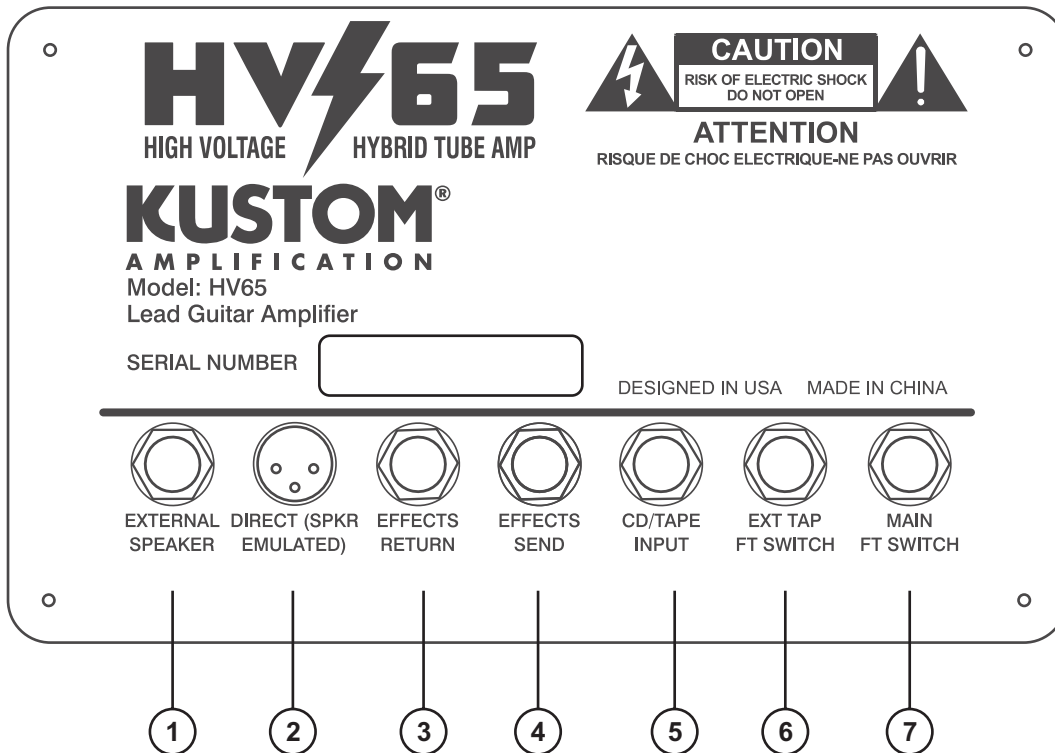

## Jacks located on chassis bottom in sequence shown above

- 1.) **External Speaker** - this is a 2-conductor 1/4" speaker output jack. Rating is 8 ohms minimum. The signal path to the internal speakers is disconnected when using this jack. Make absolute sure that a 2-conductors speaker cord is used and it is plugged in to the external speaker cabinet before plugging into this jack. Failure to do so could result in electrical shock or damage to the amplifier. It is also highly recommended to turn off the AC mains power to the amplifier before plugging or unplugging any speakers to this jack.
- 2.) **Direct (SPKR Emulated)** - this is a 3-conductor. XLR output jack for plugging into Lo-Z microphone inputs as found on PA or recording mixers. It is intended in place of external mics or used as a built-in direct box. Great effort was made in emulating the actual speaker sound.
- 3.) **Effects Return** - This switching 2-conductor 1/4" line level input jack is the return from an external signal processor such as a digital delay or EQ. By using this jack, you break the signal path between the preamp output and power amp input.
- 4.) **Effects Send** - this 2-conductor 1/4" line level output jack is the send to an external signal processor. It can also be used as a preamp output and it does not break the signal path between the power amp and preamp. The front panel volume and tone controls do affect the output of this jack. The output of the speaker is not emulated, so this is not a good choice as a substitute for mic-ing the amp.
- 5.) **CD/Tape Input** - this is a 3-conductor 1/4" line level input jack. The right and left channels are summed together on the ring and tip and sent to the preamps master mix section. The boost volume on the front panel is the only control that has any affect on this input. It acts as a master volume.
- 6.) **Ext Tap FT Switch** - this 2-conductor 1/4" switching jack replaces the Toggle Tap switch on the top panel. This is a nice feature to have, because it allows you to change the selected effect parameter in real time with your foot while playing. Using the jack disables the top panel switch. The jack accepts a non-LED single button momentary foot-switch. This foot-switch is not included with the amplifier. Kustom model KACFS-101M can be purchased separately. Most keyboard sustain pedals are this type and can also be used. NOTE: most single button foot switches used on analog instrument amplifiers are alternate contact (the "push on/push off" type). Using this type of switch will give unsatisfactory results but will not damage the amplifier.
- 7.) **Main FT Switch** - this 1/4" stereo jack connects a foot-switch to the amplifier. It uses a special circuit to decode the 3 switches through a simple stereo cable. The tip selects the rhythm or lead channel. The ring is multifunction for the overdrive on/off switch and the effects active/off switch. This foot-switch is not included with the amplifier. Kustom model KACFS-301 must be used to enjoy all the features. In an emergency, a mono single-conductor shielded instrument cable and single button foot-switch can be used to allow switching of the channels only. In this setup, the LEDs will not be visible, but at least the foot-switch will select Rhythm or Lead channels. The top panel overdrive on/off and effects active/off switches will still function.

# HV™ 65 Extras

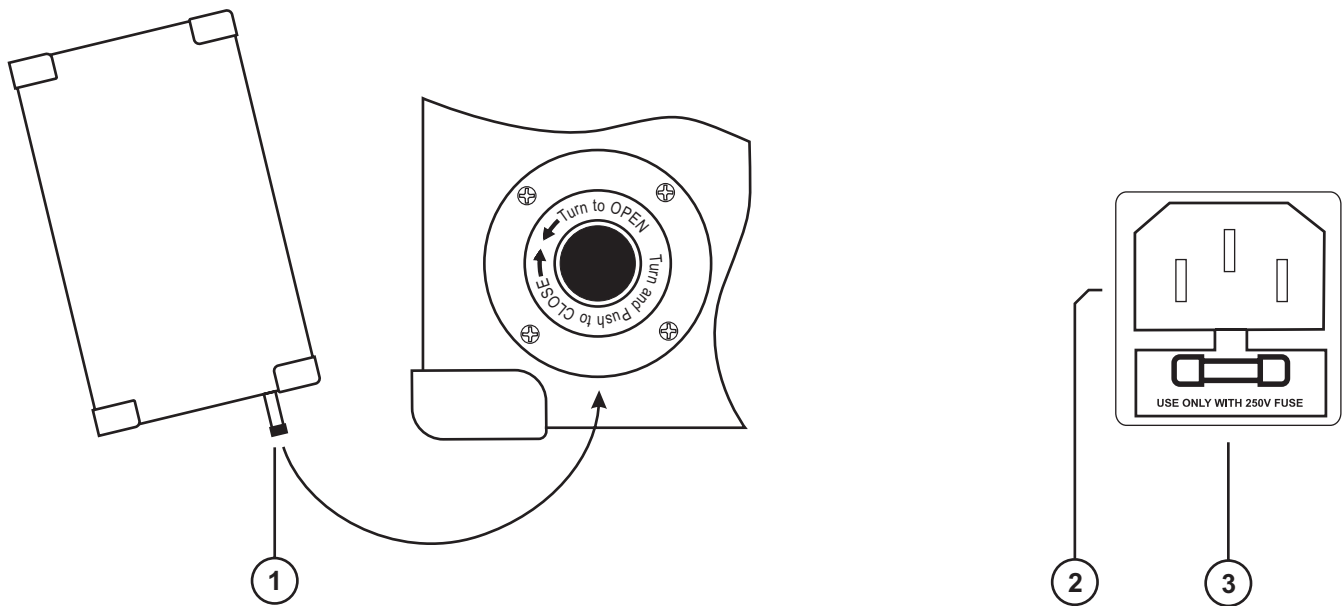

- 1.) Retractable feet** - Located on the cabinet bottom toward the front, there are two feet that extend downward to allow for tilt back operation. Twist while applying pressure to release these feet. Once extended, twist further to lock in position. Reverse process for retracting.
- 2.) AC Power Cord Receptacle** - AC power cord can be removed for easy storage and replacement if damaged. Insert the AC cord (provided) firmly into the AC receptacle. **NOTE:** Replace the AC power cord if protective jacket is damaged or ground pin is damaged or removed.
- 3.) Fuse** - The fuse is located in a fuse tray just below the receptacle. Replace only with same type and size. For your convenience, a spare fuse is located inside the fuse tray toward the front. To replace fuse, remove AC power cord. Remove fuse tray by pulling the tab located above the fuse symbol away from the receptacle.



# HV™ 65

## Specifications

|  |  |  |
|--|--|--|
| <b>Model</b>   | HV 65  | Hybrid Tube Guitar Amplifier                                     |
| <b>Tubes</b>   | Preamp   | 1-12AX7  |
| <b>Output Power</b>  | 65 Watts, RMS  | 8 Ohms @ 5% THD  |
| <b>Speakers</b>  | 1 X 12 Inch  | Celestion G12P80   |
| <b>Input Impedance</b>   | Single Input   | 100 K ohms   |
| <b>Hum &amp; Noise</b>   | -60 dBV  | Residual Noise, all level controls 0% (minimum)                  |
|  |  |  |
| <b>System Gain</b>   | 45 dBV   | Rhythm Channel Nominal gain, Volume @ 5                          |
| All measurements taken with 1 KHz input signal, Tone controls flat, Boost volume control at 0 Unless stated otherwise, Effects turned off. Measured at speaker jack with 8 ohm load. | 65 dBV   | Rhythm Channel Maximum gain, Volume @ 10                         |
|  | 50 dBV   | Lead Channel Nominal gain, Volume @ 5                            |
|  | 70 dBV   | Lead Channel Maximum gain, Volume @ 10                           |
|  | 10 dBV   | Maximum gain of footswitchable Volume Boost                      |
|  | 10 dBV   | Gain increase at 1 kHz when Gain Boost is pressed                |
|  | 6 dBV  | Gain increase at 1 kHz when Overdrive is pressed                 |
|  | 27 ~ 37 dBV  | Power amp gain (Effects Return to Speaker, depending on Boost)   |
|  |  |  |
| Nominal Signal to Noise  | 70 dBV   | Rhythm Channel, with Volume half and Master Maximum, Boost on 10 |
| Effects Loop   | 0.33 VRMS (-10 dBV)  | Levels w/Boost on 10 to reach full power output                  |
|  | 1 VRMS (0 dBV)   | Levels w/Boost on 0 to reach full power output                   |
| Footswitchable Boost   | Master Volume Boost  | Adjustable from 0 to +10dB boost AFTER the Effects Loop          |
| XLR Direct Output  |  | After power amp with speaker emulation                           |
| Digital Effects  | 24 bit DSP module, 16 effects w/programmable tap-toggle switch.                                |  |
|  |  |  |
| Footswitch   | Use KACFS301 (sold separately) to Select Rhythm/Lead, Boost, Effects On/Off                    |  |
|  | Uses a standard stereo shielded cable, but can use mono cable for emergency limited functions. |  |
|  | Use KACFS101M (sold separately) or standard momentary Footswitch with mono cable for Tap.      |  |
| Power Requirements   | USA/Canada   | 120VAC/60Hz, 120W nominal  |
|  | Europe   | 230VAC/50Hz, 120W nominal  |
|  | UK   | 230VAC/50Hz, 120W nominal  |
|  | Australia  | 240VAC/50Hz, 120W nominal  |
|  | Japan  | 100VAC/50-60Hz, 120W nominal                                     |
| Dimensions   | mm/kg  | 465 (Height) x 535 (Width) x 300 (Depth), 16.8kg                 |
|  | Inches/Pounds  | 18 (Height) x 21 (Width) x 11 3/4 (Depth), 36.7 lbs              |

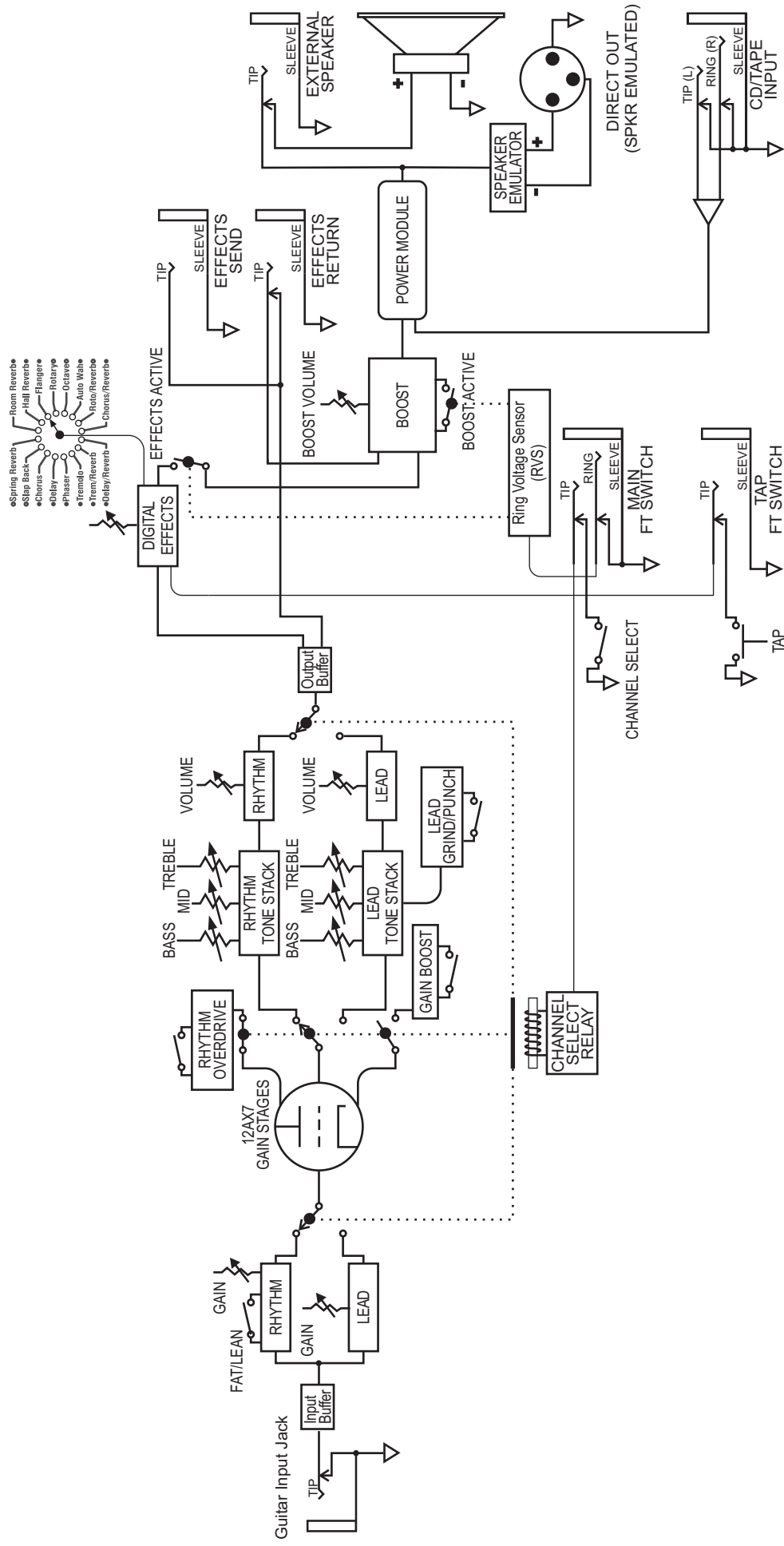

# SIGNAL FLOW DIAGRAM

# EC Declaration of Conformity

We: Kustom Musical Amplification Inc.  
4940 Delhi Pike  
Cincinnati, OH 45238  
Tel: 1-513-451-5000 Fax: 1-513-347-2192

Declare that the product

Product name: Kustom

Product model number: HV™65

to which this declaration relates is in conformity with the following standards;

|                      |   |
|----------------------|---|
| EN55013 (A12) : 1995 | Limits and methods of measurement of radio disturbance characteristics of broadcast receivers and associated equipment.             |
| EN55020: 1995        | Electromagnetic immunity of broadcast receivers and associated equipment.   |
| EN61000-3-2: 1995    | Limits for harmonic current emissions (equipment input current $\leq$ 16A per phase).   |
| EN61000-3-3: 1995    | Limitation of voltage fluctuations and flicker in low voltage supply systems for equipment with rated currents $\leq$ 16A.          |
| EN55103-1: 1995      | Electromagnetic Compatibility - Product family standard for Audio, Video Audio-visual and entertainment Lighting Control Apparatus. |
| EN60065: 1994        | Safety requirements for main operated electronic and related apparatus for household and similar general use.                       |

Following the provisions of EU Council Directive(s): 72/73 EEC and 89/336/EEC.

We the undersigned, hereby declare that the equipment specified above conforms to the aforementioned directive(s).

Name of authorized person: James Brown, Chief Engineer

Signature:  Date: 24 February 2006

Kustom Amplification Inc.  
4940 Delhi Pike  
Cincinnati, OH 45238  
Tel: 1-513-451-5000 Fax: 1-513-347-2192

